

HS-873P

Half-size Single Board Computer User's Manual

Edition: 1.2

2011/09/13



Copyright

Copyright 2009. All rights reserved. This document is copyrighted and all rights are reserved. The information in this document is subject to change without prior notice to make improvements to the products.

This document contains proprietary information and protected by copyright. No part of this document may be reproduced, copied, or translated in any form or any means without prior written permission of the manufacturer.

All trademarks and/or registered trademarks contains in this document are property of their respective owners.

Disclaimer

The company shall not be liable for any incidental or consequential damages resulting from the performance or use of this product.

The company does not issue a warranty of any kind, express or implied, including without limitation implied warranties of merchantability or fitness for a particular purpose.

The company has the right to revise the manual or include changes in the specifications of the product described within it at any time without notice and without obligation to notify any person of such revision or changes.

Trademark

All trademarks are the property of their respective holders.

Any questions please visit our website at <http://www.commell.com.tw>.

Packing List:

Please check the package material before you install the system.

Hardware:

HS-873P Single Board Computer x 1

Cable Kit:

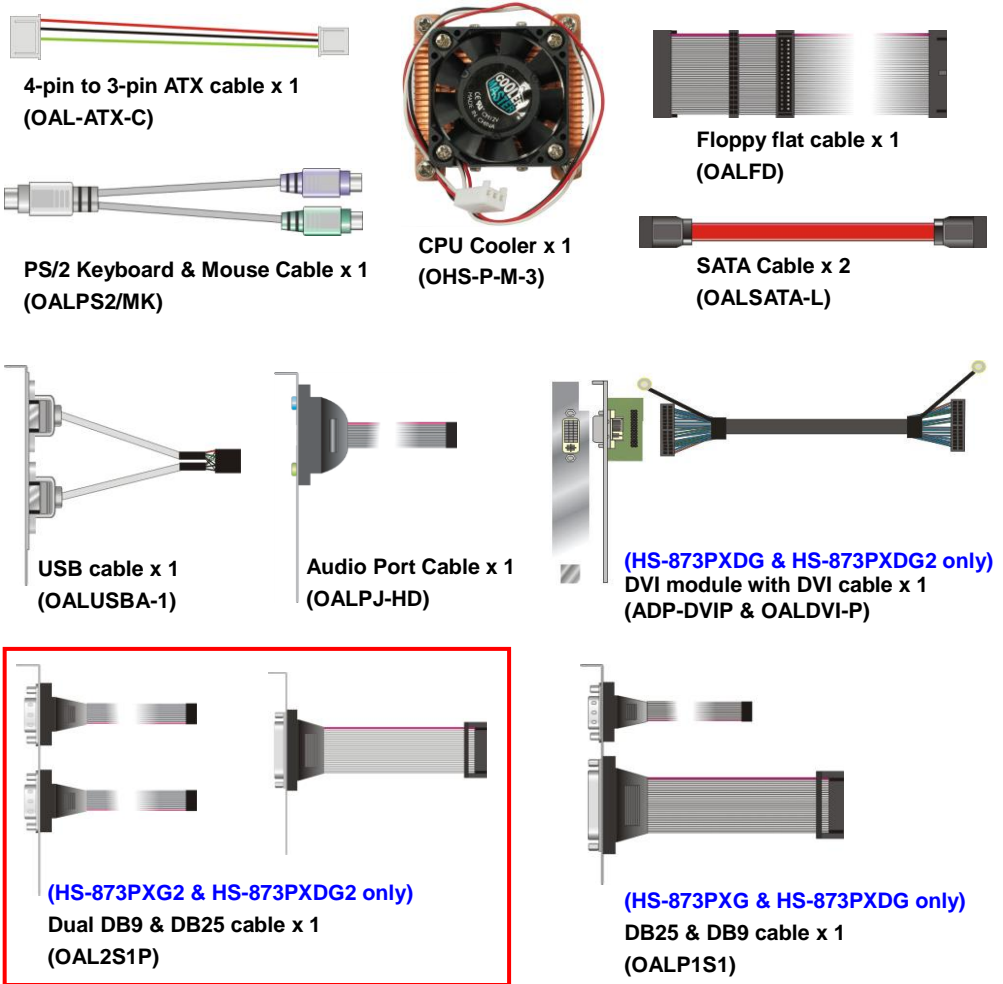

Printed Matters:

Driver CD x 1 (Including User's Manual)

Index

Chapter 1 <Introduction>	6
1.1 <Product Overview>	6
1.2 <Product Specification>	7
1.3 < Mechanical Drawing >	9
1.4 <Block Diagram>	10
Chapter 2 <Hardware Setup>	11
2.1 <Connector Location>	11
2.2.1 <Internal Connector>	13
2.2.2 <External Connector>	13
2.3 <Jumper Reference>.....	14
2.4 <CPU and Memory Setup>	15
2.4.1 <CPU Setup>	15
2.4.2 <Memory Setup>.....	16
2.5 <CMOS Setup>	17
2.6 <Serial ATA interface>.....	18
2.7 <LAN Interface>.....	18
2.8 <Onboard Display Interface>	19
2.8.1 <Analog VGA Interface>	19
2.8.2 <Digital Display>.....	20
2.8.3 <DVI Interface >	24
2.8.4 <TV-Out Interface>	25
2.9 <Onboard Audio Interface>.....	27
2.10 <USB2.0 Interface>	28
2.11 <Serial Port Jumper Setting >.....	29
2.12 <Power and Fan Installation>	30
2.12.1 <Power connectors>	30
2.12.2 <Fan Connectors>	31
2.13 <Switch and Indicator>	33

Chapter 3 <System Configuration>	34
3.1 <Audio Setting>	34
Chapter 4 <BIOS Setup>	35
Appendix A <I/O Port Pin Assignment>	36
A.1 <Parallel Port>	36
A.2 <Serial ATA Port>	36
A.3 <Floppy Port>	37
A.4 <IrDA Port>	37
A.5 <VGA Port>	38
A.6 <LAN Port>	38
A.7 <USB Port>	38
A.8 <AT Keyboard Port>	39
A.9 <PS/2 Keyboard & Mouse Port>	39
Appendix B <Flash BIOS>	40
B.1 BIOS Auto Flash Tool	40
B.2 Flash Method	40
Appendix C <System Resources>	41
C.1 <I/O Port Address Map>	41
C.2 <Memory Address Map>	43
C.3 <System IRQ Resources>	44
Appendix D <Programming GPIO's>	45
Appendix E <Watch Dog timer Setting >	46
Contact Information	47

Chapter 1 <Introduction>

1.1 <Product Overview>

The **HS-873P** is an all-in-one single board computer with PISA bus with supporting Intel Penryn processor for 667/800/1066 MHz front side bus, Intel GM45 and ICH9-M chipset, integrated GMA4500MHD graphics, DDR3 SDRAM memory, Realtek HD Audio, Serial ATA and two Intel 82574L Gigabit LAN.

Intel Penryn Processor

The board supports Intel Penryn processor with 667/800/1066 MHz front side bus, 2MB L2 cache, to provide more powerful performance than before.

New features for Intel GM45 chipset

The board integrates Intel GM45 and ICH9-M chipset, to provide new generation of the mobile solution, supports Intel GMA 4500MHD graphics, DDR3 800/1066 memory, built-in high speed mass storage interface of serial ATA, HD Audio.

All in One multimedia solution

Based on Intel GM45 and ICH9-M chipset, the board provides high performance onboard graphics, 18/24-bit Dual channel LVDS interface, HDTV and DVI.

Flexible Extension Interface

The board also provides PCI Express mini card.

1.2 <Product Specification>

General Specification

Form Factor	Half-size PISA CPU card
CPU	Intel® Penryn processor Package type: Micro-FCPGA478 (Socket-P) Front side bus: 667/800/1066 MHz
Memory	2 x 204-pin DDR3 800/1066 MHz SDRAM up to 8GB Unbuffered, none-ECC memory supported only
Chipset	Intel® GM45 and ICH9-M
BIOS	Phoenix-Award v6.00PG 4Mb PnP flash BIOS
Green Function	Power saving mode includes doze, standby and suspend modes. ACPI version 2.0 and APM version 1.2 compliant
Watchdog Timer	System reset programmable watchdog timer with 1 ~ 255 sec./min. of timeout value
Real Time Clock	Intel® ICH9-M built-in RTC with lithium battery
Serial ATA	Intel® ICH9-M integrates 3 Serial ATAII interfaces (No RAID Function)Up to 300MB/s of transfer rate

Multi-I/O Port

Chipset	Intel® ICH9-M with Winbond® W83627DHG controller
Serial Port	One RS232 and one jumper selectable RS232/422/485
USB Port	Six Hi-Speed USB 2.0 ports with 480Mbps of transfer rate
Parallel Port	One internal bi-direction parallel port with SPP/ECP/EPP mode
Floppy Port	One internal Floppy port
IrDA Port	One IrDA compliant Infrared interface supports SIR
K/B & Mouse	PS/2 keyboard and mouse port
GPIO	One 12-pin Digital I/O connector with 8-bit programmable
Smart Fan	One CPU fan connectors for fan speed controllable

VGA Display Interface

Chipset	Intel® GM45 GMCH (Graphic Memory Controller Hub)
Display Type	CRT, LCD monitor with analog display, DVI, HDTV
Connector	External DB15 female connector on rear I/O panel Onboard 40-Pin LVDS connector Onboard 26-Pin DVI connector (only HS-873PXDG, HS-873PXDG2) Onboard 9-Pin TV-out connector

Ethernet Interface

Chipset	Intel 82574L Gigabit Ethernet controller
Type	Triple speed 10/100/1000Base-T auto-switching Fast Ethernet Full duplex, IEEE802.3U compliant
Connector	External two RJ45 connectors with LED on rear I/O panel

ISA Interface

ISA Bridge	Winbond W83628AG & W83629AG
Function	I/O & IRQ supported only, no support DMA & bus mastering

Audio Interface

Chipset	Intel® ICH9M with Realtek ALC888 HD Audio Intel High Definition Audio compliance
Interface	2 channels sound output
Connector	Internal 10-pin header for line-in/-out, MIC-in, 4-pin header for CD-IN

Expansive Interface

Mini PCI	1 x PCI Express mini card
----------	---------------------------

Power and Environment

Power Requirement	DC 5V/12V power required, optional 5VSB for ATX Onboard 4-pin power connector & 3-pin ATX connector
Dimension	185 (L) x 127 (H) mm
Temperature	Operating within 0 ~ 60°C (32 ~ 140°F) Storage within -20 ~ 85°C (-4 ~ 185°F)

Ordering Code

HS-873PXG	Onboard VGA, LVDS, Audio, SATA, Giga LAN, USB2.0, Serial port, LPT, GPIO, FDD, IrDA, PCI Express mini card.
HS-873PXG2	Same as HS-873PXG and with secondary Gigabit LAN.
HS-873PXDG	Onboard VGA, LVDS, Audio, SATA, Giga LAN, USB2.0, Serial port, LPT, GPIO, FDD, IrDA, PCI Express mini card, DVI .
HS-873PXDG2	Same as HS-873PXDG and with secondary Gigabit LAN.
MPX-574D	PCI Express mini card supports single Giga LAN (Only HS-873PXG, HS-873PXG2)
MPX-SDVOD	SDVO to DVI module (HS-873PXDG, HS-873PXDG2, HS-873PXG, HS-873PXG2)

The specifications may be different as the actual board.

For further product information please visit the website at <http://www.commell.com.tw>

1.3 < Mechanical Drawing >

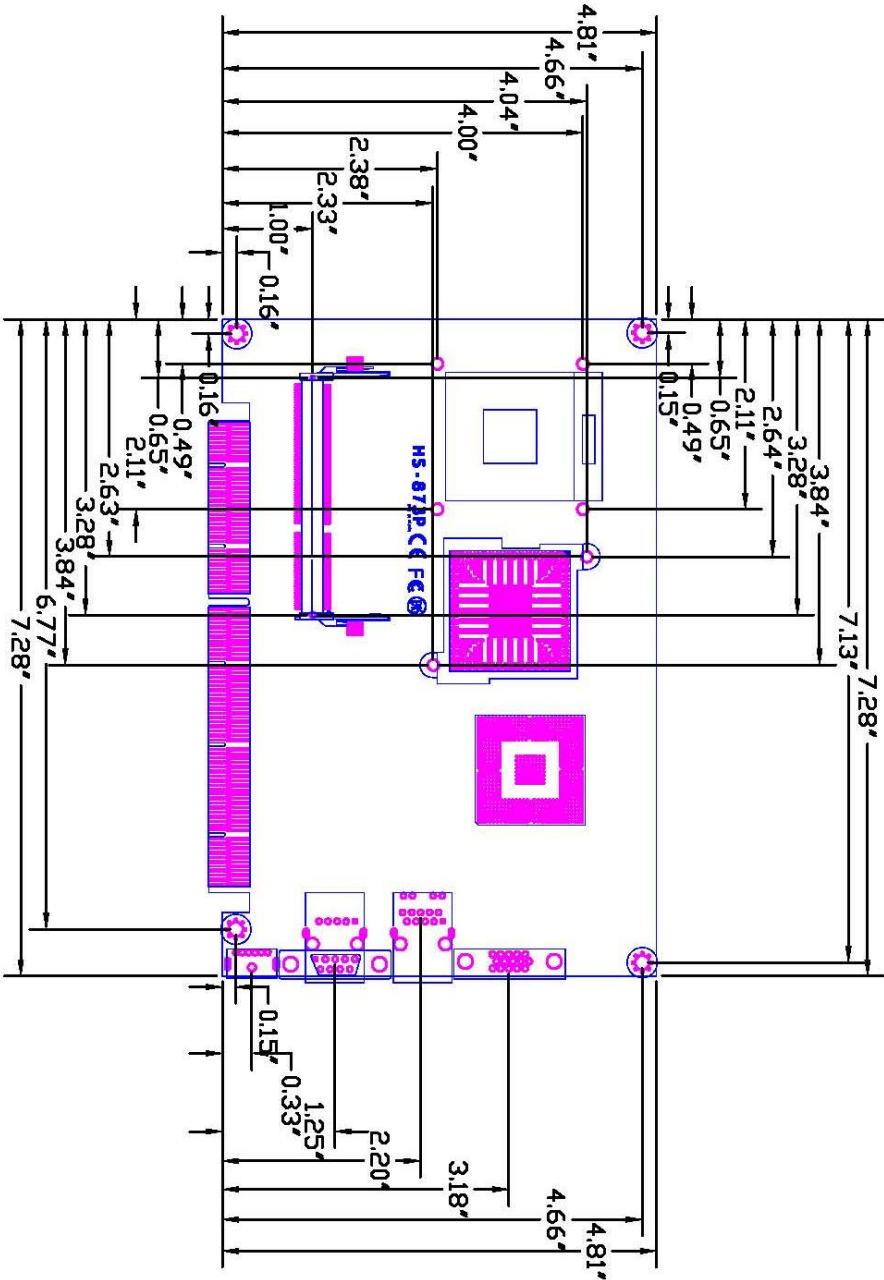

1.4 <Block Diagram>

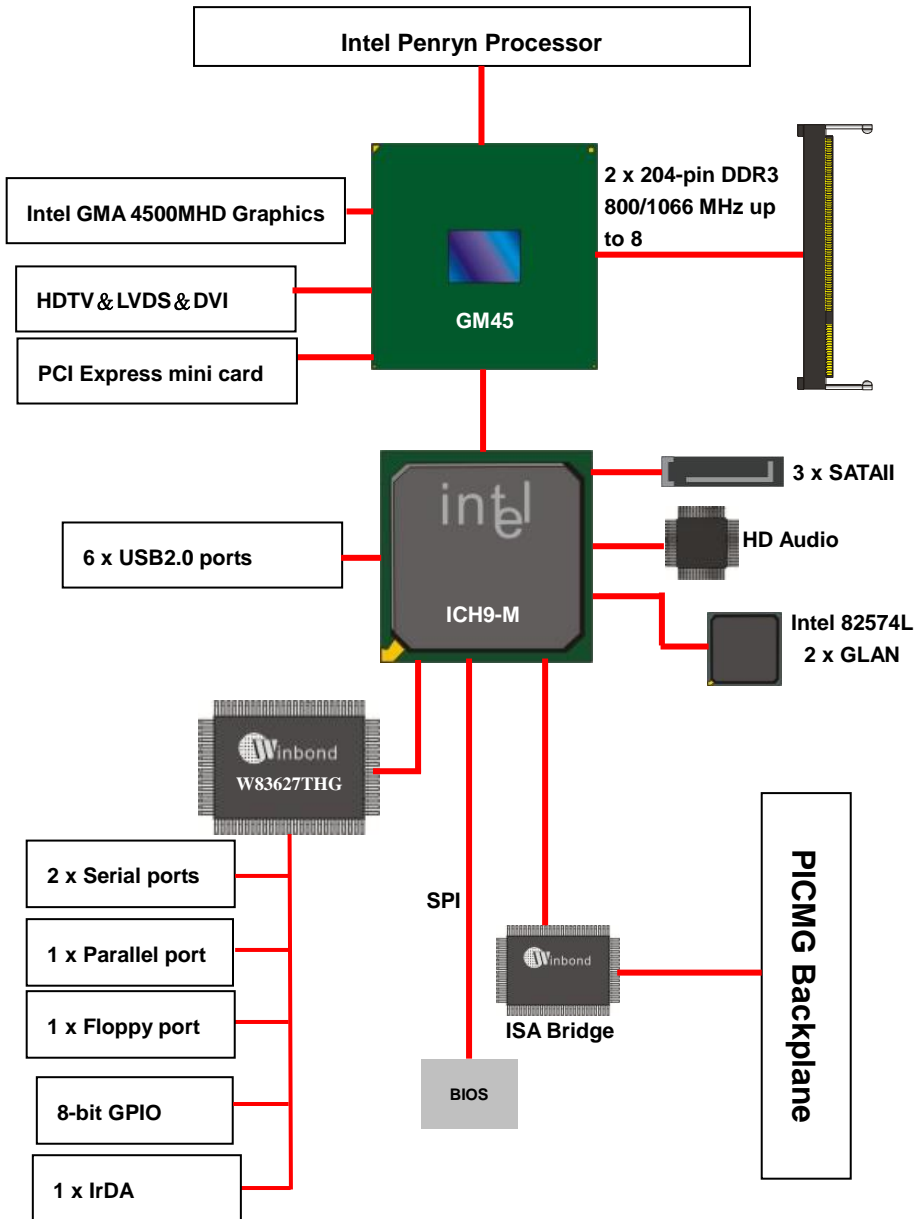

Chapter 2 <Hardware Setup>

2.1 <Connector Location>

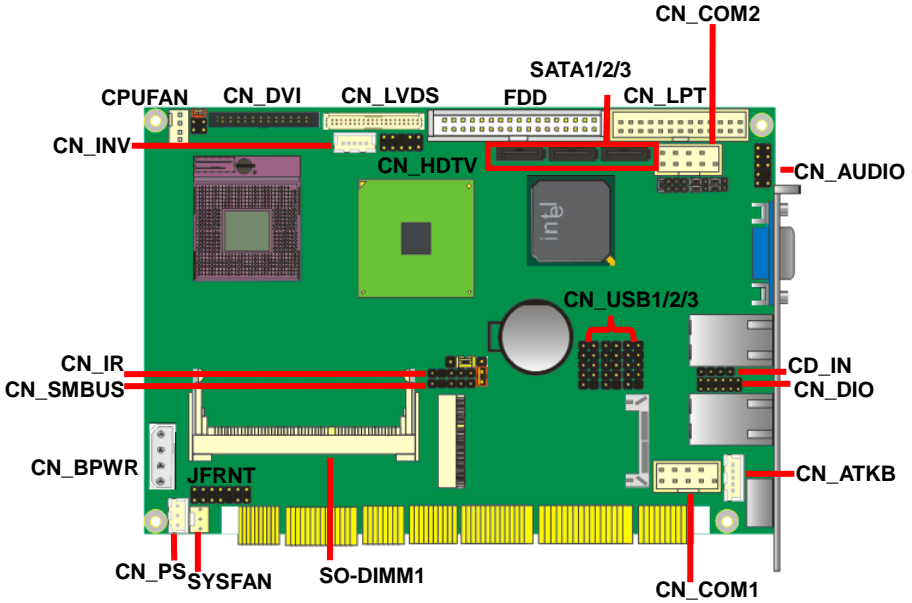

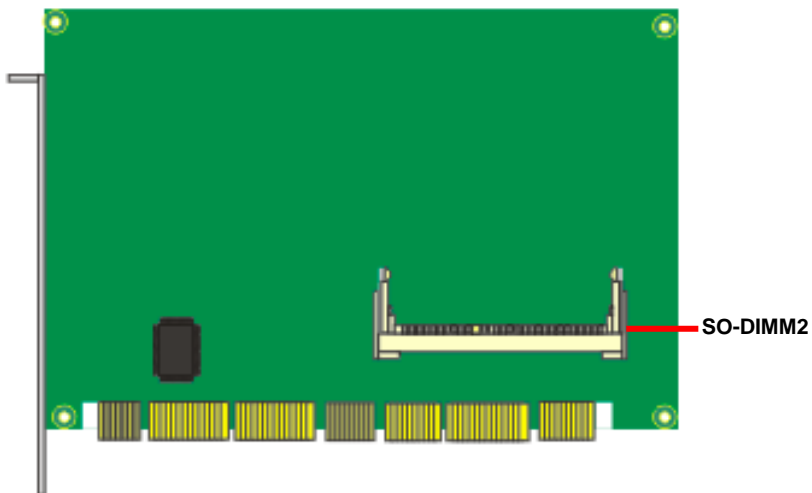

HS-873PXG2 & HS-873PXDG2

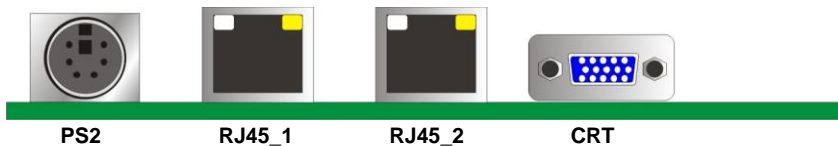

HS-873PXG & HS-873PXDG



2.2 <Connector Reference>

2.2.1 <Internal Connector>

Connector	Function	Remark
DDRIII 1/2	204-pin DDR3 SDRAM DIMM socket	Standard
FDD	26-pin floppy connector	Standard
SATA1/2/3	7-pin Serial ATA connector	Standard
CN_BPWR	4-pin AT power supply connector	Standard
CN_PS	3-pin ATX function connector	Standard
CN_AUDIO	5 x 2-pin audio connector	Standard
CDIN	4-pin CD-ROM audio input connector	Standard
CN_DIO	6 x 2-pin digital I/O connector	Slim
CN_LPT	13 x 2-pin LPT connector	Standard
CN_HDTV	5 x 2-pin HDTV interface	Standard
CN_LVDS	20 x 2-pin LVDS connector	Standard
CN_INV	5-pin LCD inverter connector	Standard
CN_USB1/2/3	5 x 2-pin USB connector	Standard
CPUFAN	4-pin CPU cooler fan connector	Standard
SYSFAN	3-pin system cooler fan connector	Standard
CN_IR	5-pin IrDA connector	Standard
CN_ATKB	5-pin AT keyboard connector	Standard
CN_DVI	26-pin TMDS connector	Standard
JFRNT	14-pin front panel switch/indicator connector	Standard
CN_COM1/2	10-pin serial port connector	Standard
MINI_Card	52-pin PCI Express mini card	Standard

2.2.2 <External Connector>

Connector	Function	Remark
CRT	DB15 VGA connector	Standard
RJ45_1/2	One RJ45 LAN connector	Standard
PS2	PS/2 keyboard and mouse connector	Standard

2.3 <Jumper Reference>

Jumper	Function
JRTC	CMOS Operating/Clear Setting
JVLCD	LCD Panel Voltage Setting
JCSEL1/2	COM2 RS232/422/485 mode setting
JAT	Power mode select

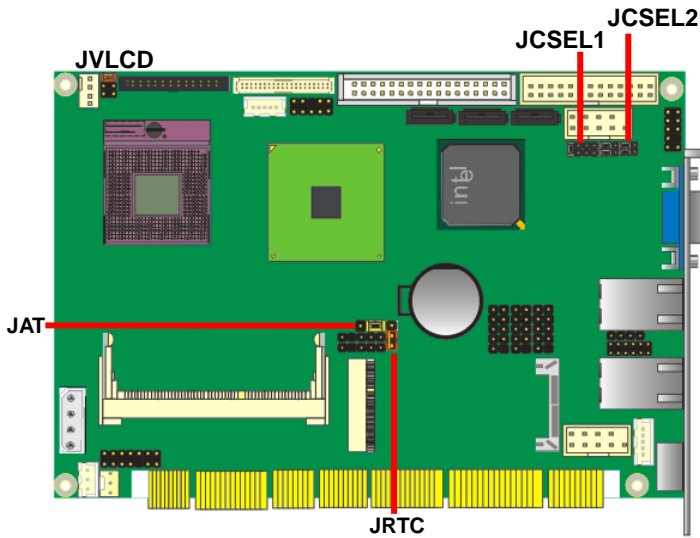

2.4 <CPU and Memory Setup>

2.4.1 <CPU Setup>

The board comes with the socket 478 for Intel Penryn **Socket-P** processor only it supports new generation with 667/800/1066 MHz of front side bus. Please follow the instruction to install the CPU properly.

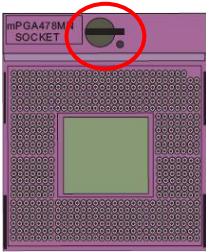

1. Use the flat-type screw drive to unlock the CPU socket

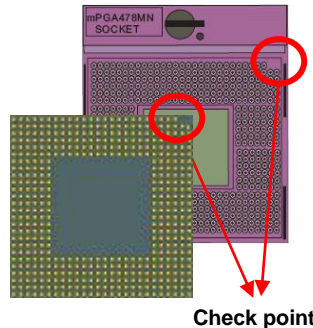

2. Follow the pin direction to install the processor on the socket

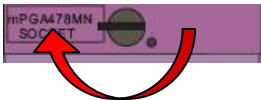

3. Lock the socket

4. Socket P has 478 pins, but is not pin-compatible with Socket P CPU.

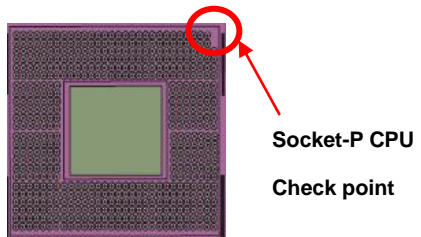

2.4.2 <Memory Setup>

HS-873P has two 204-pin DDR3 DIMM support up to 8GB of memory capacity. The memory frequency supports 800/1066 MHz. Only Non-ECC memory is supported. **Dual-Channel technology** is supported while applying two same modules on one of each group.

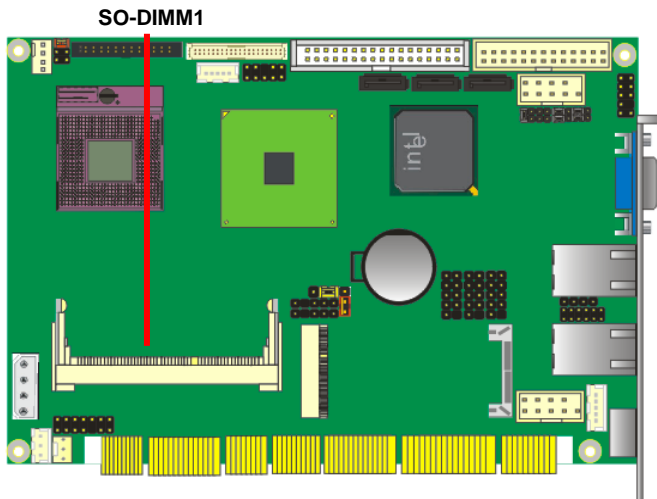

2.5 <CMOS Setup>

The board's data of CMOS can be setting in BIOS. If the board refuses to boot due to inappropriate CMOS settings, here is how to proceed to clear (reset) the CMOS to its default values.

Jumper: JRTC

Type: Onboard 3-pin jumper

JRTC	Mode
1-2	Clear CMOS
2-3	Normal Operation

Default setting

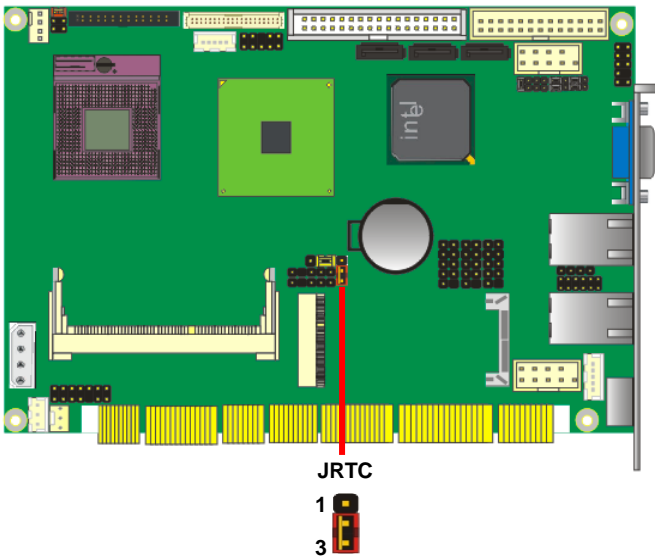

2.6 <Serial ATA interface>

Based on Intel ICH9-M, the board provides two Serial ATAII interfaces with up to 300MB/s of transfer rate.

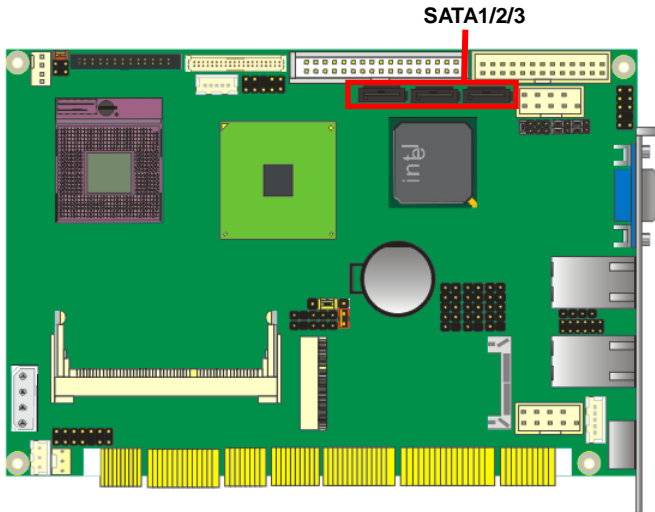

2.7 <LAN Interface>

The Intel 82574L supports triple speed of 10/100/1000Base-T, with IEEE802.3 compliance and Wake-On-LAN supported.

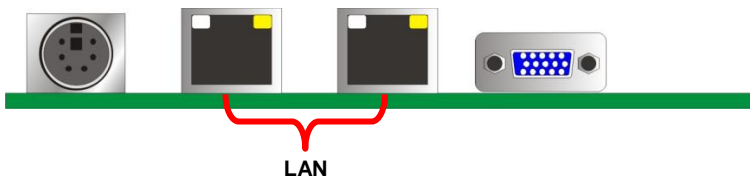

2.8 <Onboard Display Interface>

Based on Intel GM45 chipset with built-in GMA (Graphic Media Accelerator) 4500MHD graphics, the board provides one DB15 connector on rear external I/O port, and one 40-pin LVDS interface with 5-pin LCD backlight inverter connector. The board provides dual display function with clone mode and extended desktop mode for CRT and LCD and TV-out and DVI (**HS-873PXDG/G2**).

2.8.1 <Analog VGA Interface>

Please connect your CRT or LCD monitor with DB15 male connector to the onboard DB15 female connector on rear I/O port.

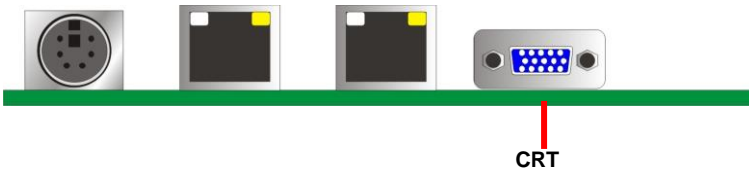

2.8.2 <Digital Display>

The board provides one 40-pin LVDS connector for 18/24-bit dual channel panels, supports up to 1600 x 1200 (UXGA) of resolution, with one LCD backlight inverter connector and one jumper for panel voltage setting.

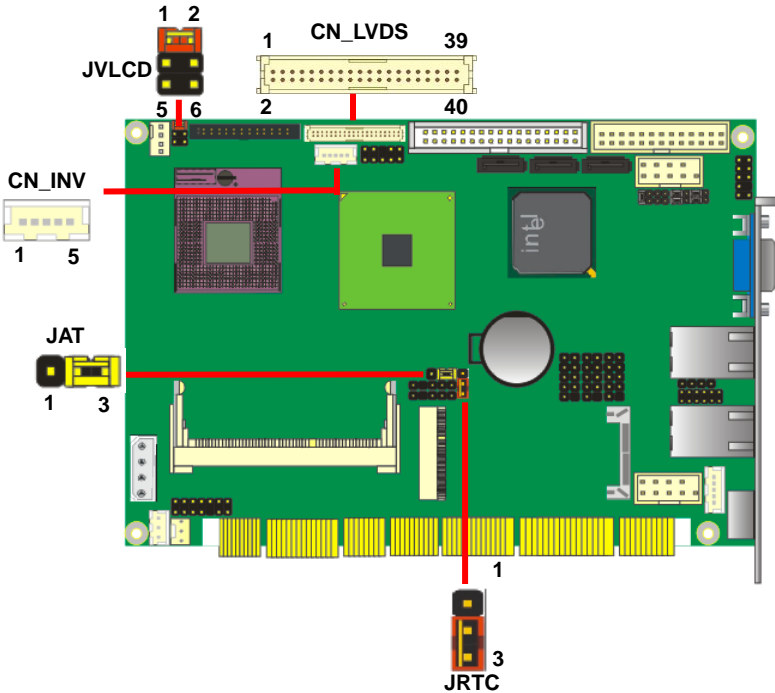

Connector: **CN_INV**

Type: 5-pin LVDS Power Header

Pin	Description
1	+12V
2	Reserved (Note)
3	GND
4	GND
5	ENABKL

Note: Reserved for MB internal test
Please treat it as NC.

Connector: **JVLCD**

Type: 6-pin Power select Header

Pin	Description
1-2	LCDVCC (3.3V)
3-4	LCDVCC (5V)
5-6	LCDVCC (12V)

Default: 1-2

Connector: **CN_LVDS**

Type: onboard 40-pin connector for LVDS connector

Connector model: **HIROSE DF13-40DP-1.25V**

Pin	Signal	Pin	Signal
2	LCDVCC	1	LCDVCC
4	GND	3	GND
6	ATX0-	5	BTX0-
8	ATX0+	7	BTX0+
10	GND	9	GND
12	ATX1-	11	BTX1-
14	ATX1+	13	BTX1+
16	GND	15	GND
18	ATX2-	17	BTX2-
20	ATX2+	19	BTX2+
22	GND	21	GND
24	ACLK-	23	BTX3-
26	ACLK+	25	BTX3+
28	GND	27	GND
30	ATX3-	29	BCLK-
32	ATX3+	31	BCLK+
34	GND	33	GND
36	DDCPCLK	35	N/C
38	DDCPDATA	37	N/C
40	N/C	39	N/C

To setup the LCD, you need the component below:

1. A panel with LVDS interfaces.
2. An inverter for panel's backlight power.
3. A LCD cable and an inverter cable.

For the cables, please follow the pin assignment of the connector to make a cable, because every panel has its own pin assignment, so we do not provide a standard cable; please find a local cable manufacture to make cables.

LCD Installation Guide:

1. Preparing the **HS-873P**, LCD panel and the **backlight inverter**.

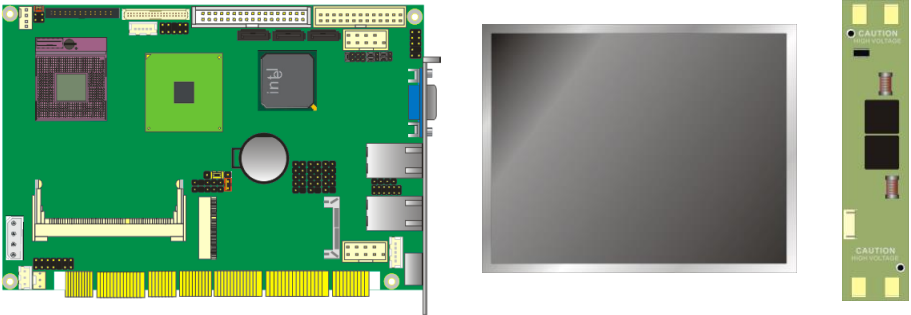

2. Please check the datasheet of the panel to see the voltage of the panel, and set the jumper **JVLCD** to +12V or +5V or +3.3V.
3. You would need a LVDS type cable.

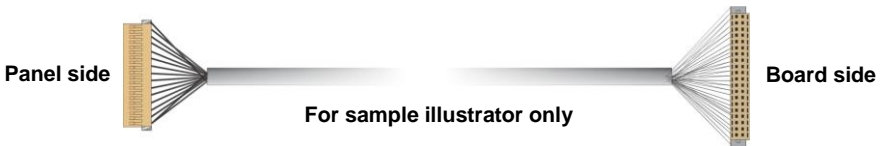

4. To connect all of the devices well.

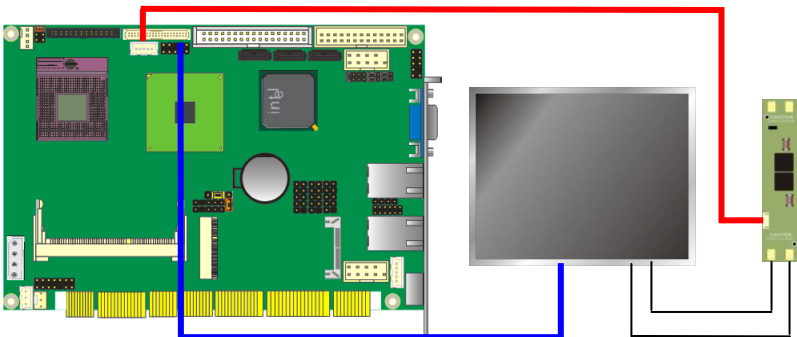

HS-873P User's Manual

The board also comes with a DVI interface with Chrontel CH7307C for digital video interface.

After setup the devices well, you need to select the LCD panel type in the BIOS.

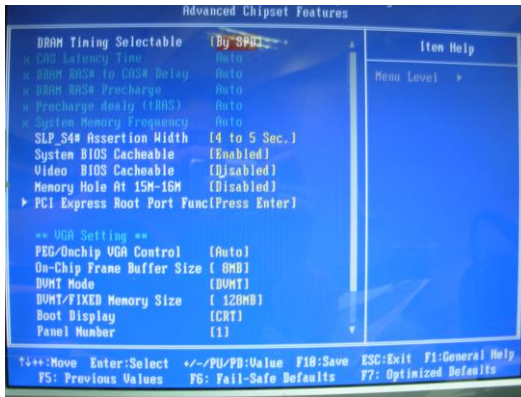

The panel type mapping is list below:

BIOS panel type selection form (BIOS Version:1.0)			
18-bit Single channel		24-bit Dual channel	
NO.	Output format	NO.	Output format
1	640 x 480	11	1280 x 768
2	800 x 480	12	1280 x 1024
3	800 x 600	13	1600 x 1200
4	1024 x 768	14	1920 x 1080
5	1280 x 800	15	1920 x 1200
18-bit Dual channel			
6	1280 x 768		
24-bit Single channel			
7	1024 x 768		
8	1280 x 768		
9	1280 x 800		
10	1366 x 768		

2.8.3 <DVI Interface >

Connector: **CN_DVI**

Connector type: 26-pin header connector (pitch = 2.00mm)

Pin Number	Assignment	Pin Number	Assignment
1	TX1+	2	TX1-
3	Ground	4	Ground
5	TXC+	6	TXC-
7	Ground	8	PVDD
9	N/C	10	N/C
11	TX2+	12	TX2-
13	Ground	14	Ground
15	TX0+	16	TX0-
17	N/C	18	HPDET
19	DDCDATA	20	DDCCLK
21	GND	22	N/C
23	N/C	24	N/C
25	N/C	26	N/C

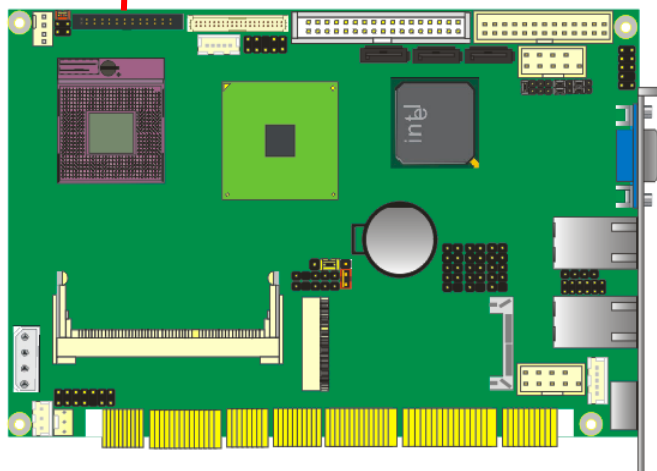

2.8.4 <TV-Out Interface>

The board provides an HDTV interface with Intel GM45, supports PAL and NTSC of TV system, and display (clone or extended desktop) function with CRT, LVDS, DVI.

Connector: **CN_HDTV**

Connector type: 10-pin header HDTV connector (pitch = 2.54mm)

Pin Number	Assignment	Pin Number	Assignment
1	GND	2	DACC_L
3	DACC_L	4	GND
5	GND	6	N/C
7	DACA_L	8	GND
9	N/C	10	N/C

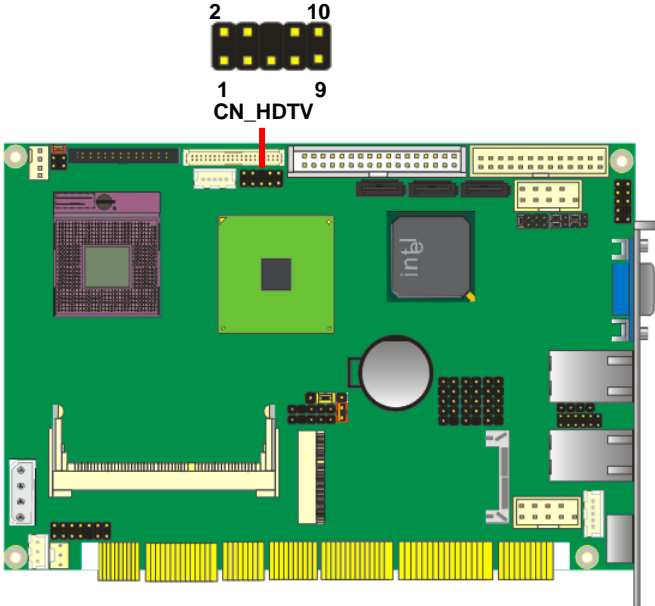

To connect the TV set, please follow the diagram below to setup your system:

**YPrPb Component Cable
(For HDTV)**

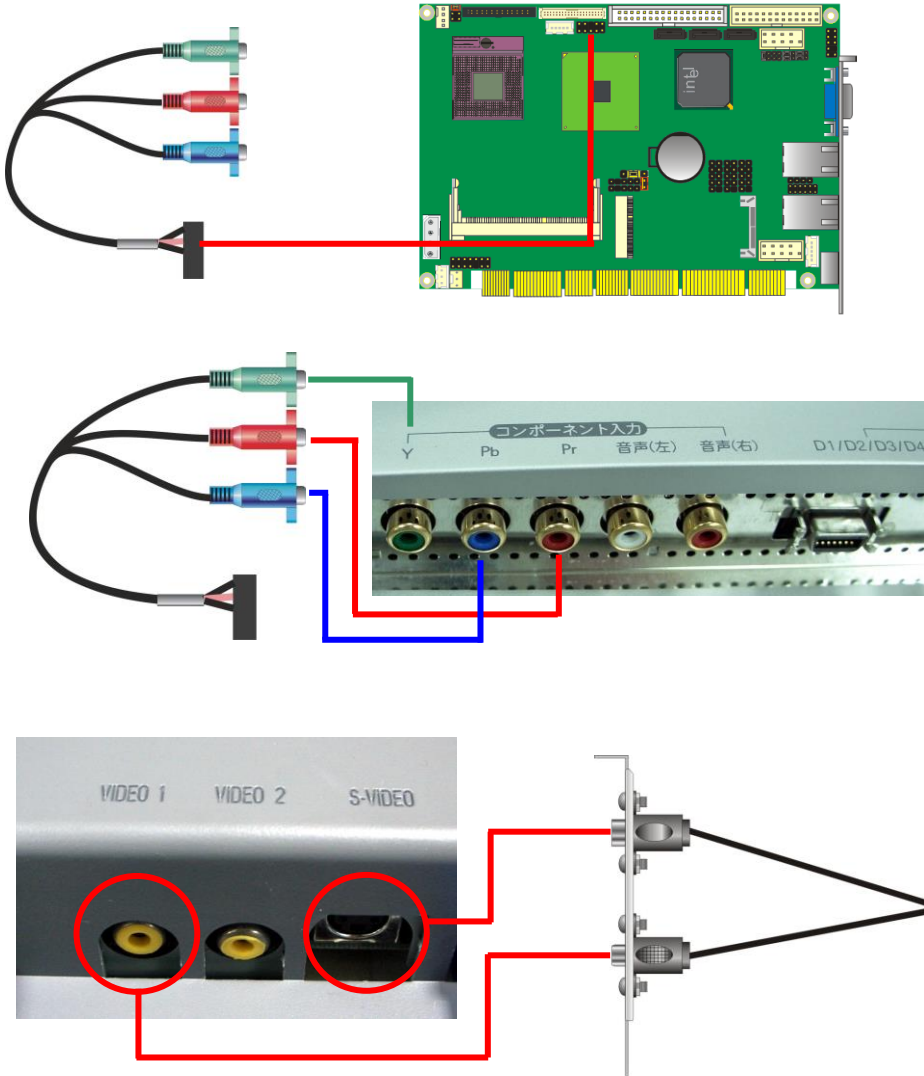

2.9 <Onboard Audio Interface>

The board provides the onboard HD audio interface with Realtek ALC888

Connector: CN_AUDIO

Type: 10-pin (2 x 5) 1.27mm x 2.54mm-pitch header

Pin	Description	Pin	Description
1	MIC2_L	2	Ground
3	MIC2_R	4	VCC
5	FP_OUT_R	6	MIC2_JD
7	SENSE_B	8	N/C
9	FP_OUT_L	10	LINE2_JD

Connector: CDIN

Type: 4-pin header (pitch = 2.54mm)

Pin	Description
1	CD – Left
2	Ground
3	Ground
4	CD – Right

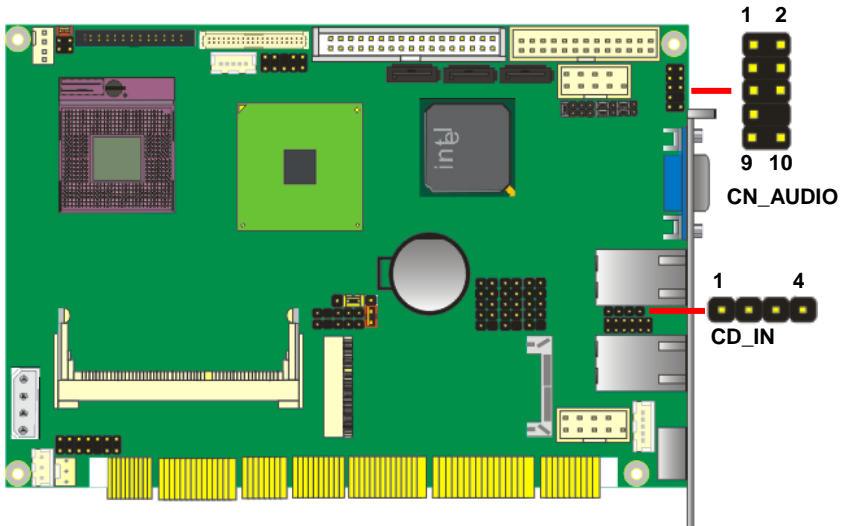

2.10 <USB2.0 Interface>

Based on Intel ICH9-M, the board provides 6 USB2.0 ports. The USB2.0 interface provides up to 480Mbps of transferring rate.

Interface	USB2.0
Controller	ICH9-M
Transfer Rate	Up to 480Mb/s
Output Voltage	500mA

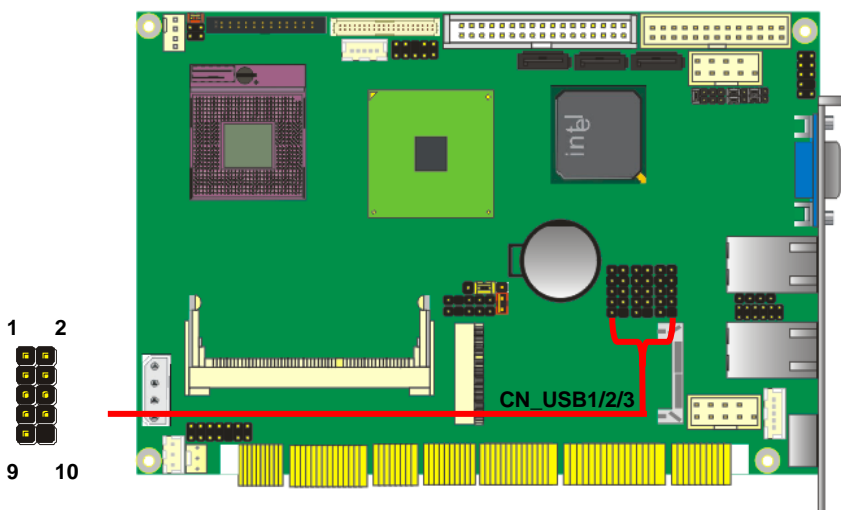

Connector: **CN_USB1/2/3**

Type: 10-pin (5 x 2) header for USB Port

Pin	Description	Pin	Description
1	VCC	2	VCC
3	Data0-	4	Data1-
5	Data0+	6	Data1+
7	Ground	8	Ground
9	Ground	10	N/C

PS: The USB2.0 will be only active when you connecting with the USB2.0 devices, if you insert an USB1.1 device, the port will be changed to USB1.1 protocol automatically. The transferring rate of USB2.0 as 480Mbps is depending on device capacity, exact transferring rate may not be up to 480Mbps.

2.11 <Serial Port Jumper Setting >

The board supports one RS232 serial port and one jumper selectable RS232/422/485 serial ports. The jumper JCSEL1 & JCSEL2 can let you configure the communicating modes for COM2.

Connector: **CN_COM1**

Type: 10-pin (5 x 2) 2.54mm x 2.54mm-pitch header for COM1







Pin	Description	Pin	Description
1	DCD	2	RXD
3	TXD	4	DTR
5	GND	6	DSR
7	RTS	8	CTS
9	RI	10	N/C

Connector: **CN_COM2**

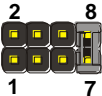
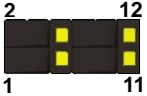
Type: 10-pin (5 x 2) 2.54mm x 2.54mm-pitch header for COM2

Pin	Description	Pin	Description
1	DCD/422TX-/485-	2	RXD/422TX+/485+
3	TXD/422RX+	4	DTR/422RX-
5	GND	6	DSR
7	RTS	8	CTS
9	RI	10	N/C

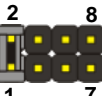
Setting RS-232, RS-422, RS-485 & IrDA:

Function	JCSEL1	JCSEL2
IrDA		
RS-422		
RS-485		
RS-232		

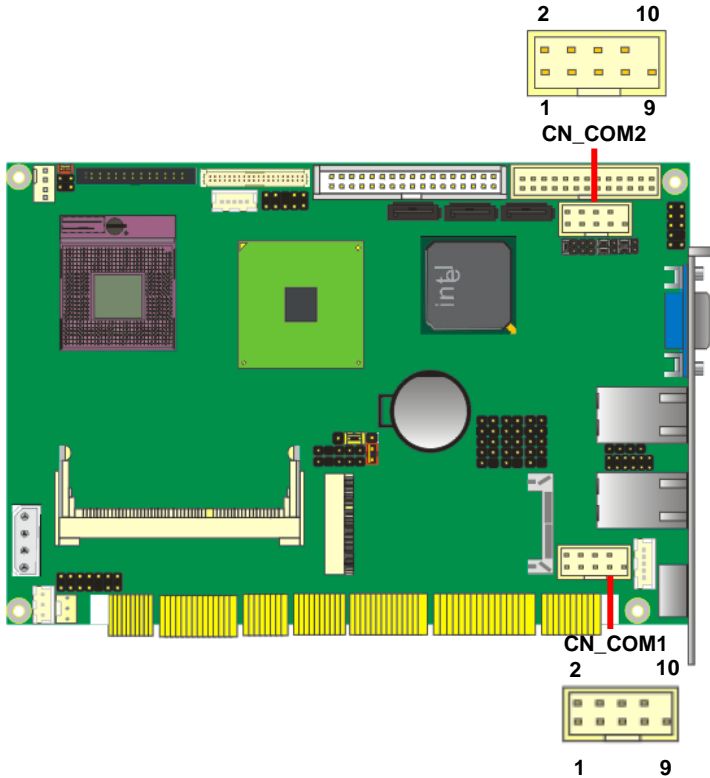

2.12 <Power and Fan Installation>

The board comes with a 4-pin AT power connector for powering the board, three fan connectors for Northbridge, CPU and system. The board also provides a 3-pin ATX function connector. You can just connect the two power connectors without any backplane to work.

2.12.1 <Power connectors>

Connector: **CN_BPWR**

Type: 4-pin P-type connector for +5V/+12V input

Pin	Description	Pin	Description	Pin	Description	Pin	Description
1	+12V	2	Ground	3	Ground	4	+5V

Connector: **CN_PS**

Type: 3-pin ATX function connector

Pin	Description	Pin	Description	Pin	Description
1	5V Standby	2	Ground	3	Power On

2.12.2 <Fan Connectors>

Connector: **CPUFAN**

Type: 4-pin fan wafer connector

Pin	Description	Pin	Description
1	Ground	2	+12V
3	Fan Speed Detection	4	Fan Control

Connector: **SYSFAN**

Type: 3-pin fan wafer connector

Pin	Description	Pin	Description	Pin	Description
1	Ground	2	+12V	3	Fan Speed Detection

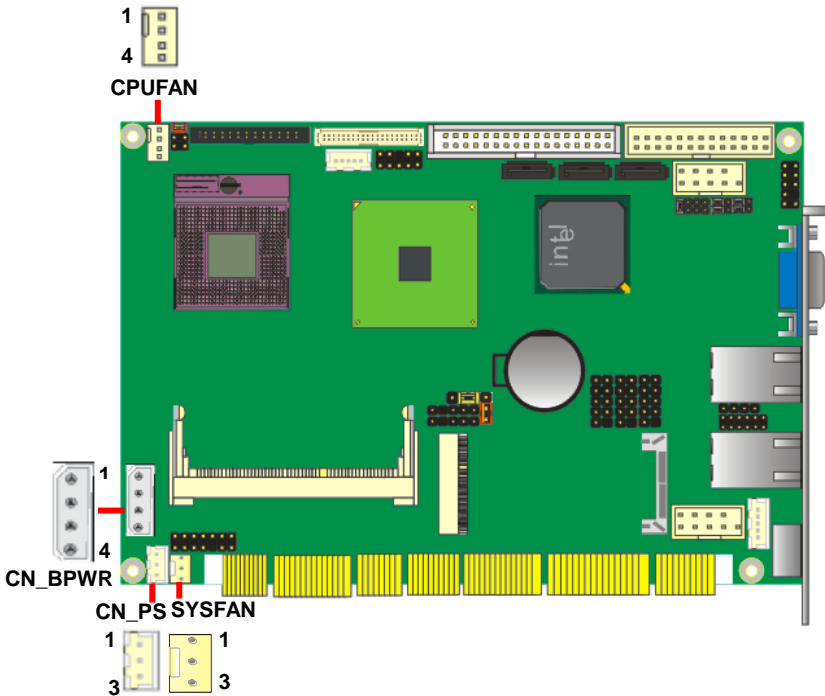

2.13 <GPIO Interface>

The board provides a 12-pin General Purpose I/O interface, with programmable 8-bit I/O (4-bit input & 4-bit output).

Connector: **CN_DIO**

Type: onboard 2 x 6-pin header, pitch=2.0mm

Pin	Description	Pin	Description
1	Ground	2	Ground
3	GP10	4	GP14
5	GP11	6	GP15
7	GP12	8	GP16
9	GP13	10	GP17
11	VCC	12	+12V

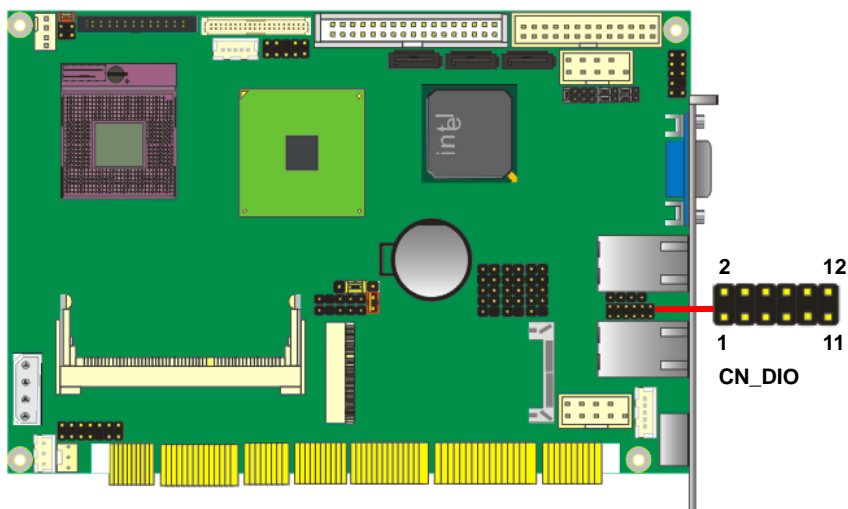

2.13 <Switch and Indicator>

The **JFRNT** provides front control panel of the board, such as power button, reset and beeper, etc. Please check well before you connecting the cables on the chassis.

Connector: **JFRNT**

Type: onboard 14-pin (2 x 7) 2.54-pitch header

Function	Signal	PIN		Signal	Function
IDE LED	Vcc (+)	1	2	Vcc (+)	Power LED
	Active	3	4	N/C	
Reset	Reset	5	6	GND	Speaker
	GND	7	8	Vcc	
N/C		9	10	N/C	
Power Button	PWRBT	11	12	N/C	
	GND	13	14	SPKIN	

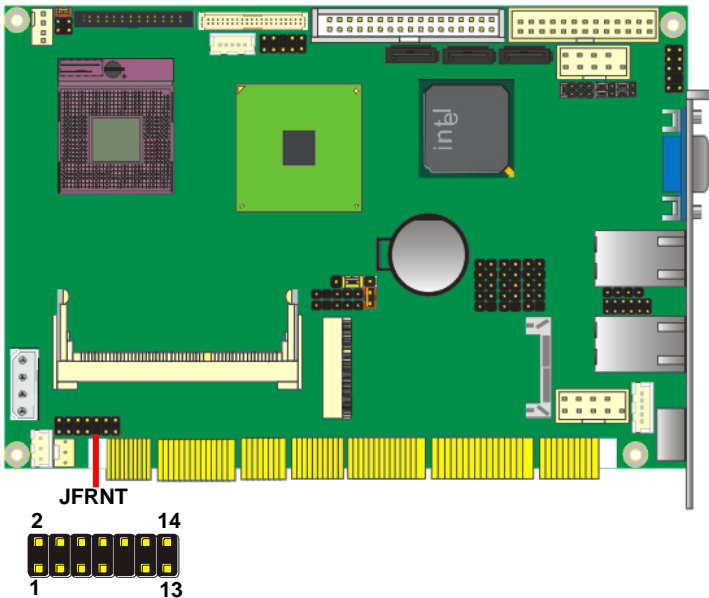

Chapter 3 <System Configuration>

3.1 <Audio Setting>

The board integrates Intel® ICH9M with REALTEK® ALC888 codec. It can support 2 channels sound under system configuration. Please follow the steps below to setup your sound system.

1. Install REALTEK HD Audio driver.
2. Lunch the control panel and Sound Effect Manager.

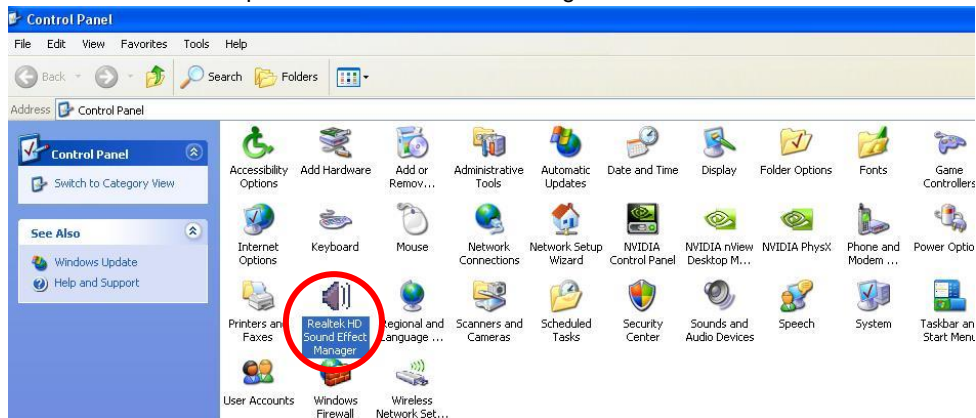

3. Select Speaker Configuration



4. Select the sound mode to meet your speaker system.

Chapter 4 <BIOS Setup>

The motherboard uses the Award BIOS for the system configuration. The Award BIOS in the single board computer is a customized version of the industrial standard BIOS for IBM PC AT-compatible computers. It supports Intel x86 and compatible CPU architecture based processors and computers. The BIOS provides critical low-level support for the system central processing, memory and I/O sub-systems.

The BIOS setup program of the single board computer let the customers modify the basic configuration setting. The settings are stored in a dedicated battery-backed memory, NVRAM, retains the information when the power is turned off. If the battery runs out of the power, then the settings of BIOS will come back to the default setting.

The BIOS section of the manual is subject to change without notice and is provided here for reference purpose only. The settings and configurations of the BIOS are current at the time of print, and therefore they may not be exactly the same as that displayed on your screen.

To activate CMOS Setup program, press key immediately after you turn on the system. The following message "Press DEL to enter SETUP" should appear in the lower left hand corner of your screen. When you enter the CMOS Setup Utility, the Main Menu will be displayed as **Figure 4-1**. You can use arrow keys to select your function, press <Enter> key to accept the selection and enter the sub-menu.

Figure 4-1 CMOS Setup Utility Main Screen

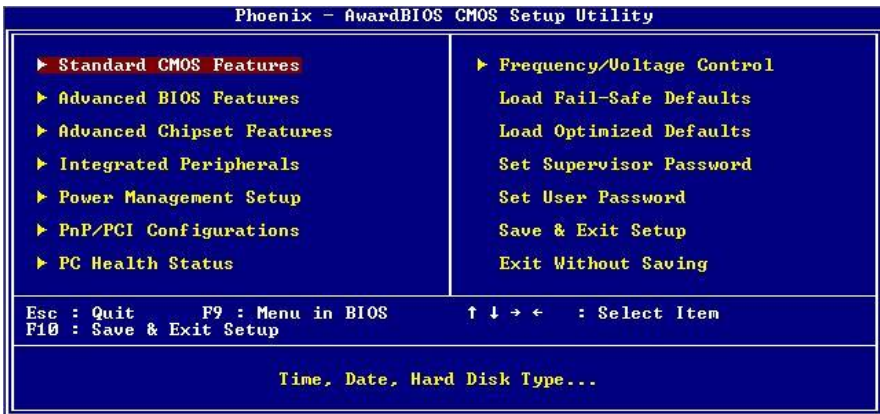

Appendix A <I/O Port Pin Assignment>

A.1 <Parallel Port>

Connector: **LPT**

Type: 26-pin (13 x 2) box header

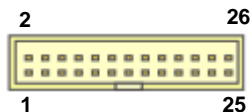

Pin	Description	Pin	Description
1	-PSTB	14	AFD-
2	PRO0	15	ERR-
3	PRO1	16	INT-
4	PRO2	17	SLIN-
5	PRO3	18	Ground
6	PRO4	19	Ground
7	PRO5	20	Ground
8	PRO6	21	Ground
9	PRO7	22	Ground
10	ACK-	23	Ground
11	BUSY	24	Ground
12	PE	25	Ground
13	SLCT	26	N/C

A.2 <Serial ATA Port>

Connector: **SATA1/2/3**

Type: 7-pin wafer connector

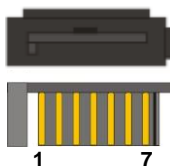

1	2	3	4	5	6	7
GND	RSATA_TXP1	RSATA_TXN1	GND	RSATA_RXN1	RSATA_RXP1	GND

A.3 <Floppy Port>

Connector: **FDD**

Type: 34-pin connector

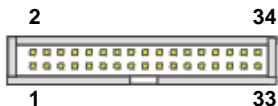

Pin	Description	Pin	Description
1	VCC	2	INDEX
3	VCC	4	DR0
5	VCC	6	DSKCHG
7	N/C	8	N/C
9	N/C	10	MTR0
11	DRVDE0	12	DIR
13	N/C	14	STEP
15	Ground	16	WRITE DATA
17	Ground	18	WRITE GATE
19	Ground	20	TRAK 0
21	N/C	22	WRPT0
23	Ground	24	RDATA-
25	Ground	26	HDSEL

A.4 <IrDA Port>

Connector: **CN_IR**

Type: 5-pin header for SIR Ports

Pin	Description
1	VCC
2	N/C
3	IRRX
4	Ground
5	IRTX



A.5 <VGA Port>

Connector: **CRT**

Type: 15-pin D-sub female connector on bracket

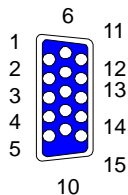

Pin	Description	Pin	Description	Pin	Description
1	RED	6	Ground	11	N/C
2	GREEN	7	Ground	12	5VCCA
3	BLUE	8	Ground	13	HSYNC
4	N/C	9	LVGA5V	14	VSYNC
5	Ground	10	Ground	15	5VCLK

A.6 <LAN Port>

Connector: **RJ45_1/2**

Type: RJ45 connector with LED on rear panel



Pin	1	2	3	4	5	6	7	8
Description	MI0+	MI0-	MI1+	MI2+	MI2-	MI1-	MI3+	MI3-

A.7 <USB Port>

Connector: **CN_USB1/2/3**

Type: 10-pin (5 x 2) header for dual USB Ports

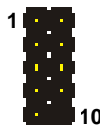

Pin	Description	Pin	Description
1	VCC	2	VCC
3	Data0-	4	Data1-
5	Data0+	6	Data1+
7	Ground	8	Ground
9	Ground	10	N/C

A.8 <AT Keyboard Port>

Connector: **CN_ATKB**

Type: 5-pin box header

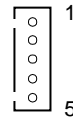

Pin	1	2	3	4	5
Description	VCC	Ground	N/C	DATA	CLK

A.9 <PS/2 Keyboard & Mouse Port>

Connector: **PS2**

Type: 6-pin Mini-DIN connector on bracket

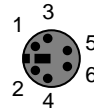

Pin	1	2	3	4	5	6
Description	KBD	MSD	Ground	VCC	KBC	MSC

Note: The PS/2 connector supports standard PS/2 keyboard directly or both PS/2 keyboard and mouse through the PS/2 Y-type cable.

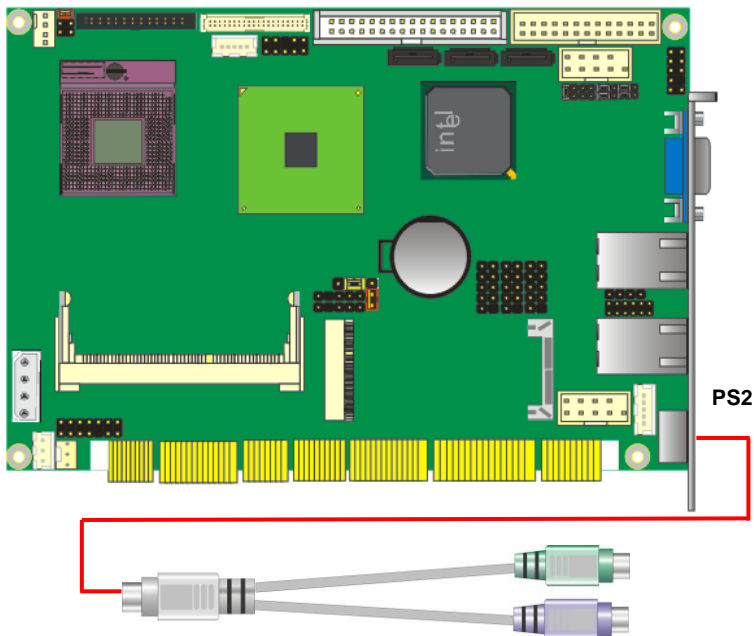

Appendix B <Flash BIOS>

B.1 BIOS Auto Flash Tool

The board is based on Award BIOS and can be updated easily by the BIOS auto flash tool. You can download the tool online at the address below:

<http://www.award.com>

<http://www.commell.com.tw/support/support.htm>

File name of the tool is "awdf flash.exe", it's the utility that can write the data into the BIOS flash chip and update the BIOS.

B.2 Flash Method

1. Please make a bootable floppy disk.
2. Get the last .bin files you want to update and copy it into the disk.
3. Copy awardflash.exe to the disk.
4. Power on the system and flash the BIOS. (Example: C:/ awardflash XXX.bin)
5. Re-start the system.

Any question about the BIOS re-flash please contact your distributors or visit the web-site at below:

<http://www.commell.com.tw/support/support.htm>

Appendix C <System Resources>

C.1 <I/O Port Address Map>

[00000000 - 0000000F]	Direct memory access controller
[00000000 - 00000CF7]	PCI bus
[00000010 - 0000001F]	Motherboard resources
[00000020 - 00000021]	Programmable interrupt controller
[00000022 - 0000003F]	Motherboard resources
[00000040 - 00000043]	System timer
[00000044 - 0000005F]	Motherboard resources
[00000060 - 00000060]	Standard 101/102-Key or Microsoft Natural PS/2 Keyboard
[00000061 - 00000061]	System speaker
[00000062 - 00000063]	Motherboard resources
[00000064 - 00000064]	Standard 101/102-Key or Microsoft Natural PS/2 Keyboard
[00000065 - 0000006F]	Motherboard resources
[00000070 - 00000073]	System CMOS/real time clock
[00000074 - 0000007F]	Motherboard resources
[00000080 - 00000090]	Direct memory access controller
[00000091 - 00000093]	Motherboard resources
[00000094 - 0000009F]	Direct memory access controller
[000000A0 - 000000A1]	Programmable interrupt controller
[000000A2 - 000000BF]	Motherboard resources
[000000C0 - 000000DF]	Direct memory access controller
[000000E0 - 000000EF]	Motherboard resources
[000000F0 - 000000FF]	Numeric data processor
[00000274 - 00000277]	ISAPNP Read Data Port
[00000279 - 00000279]	ISAPNP Read Data Port
[000002F8 - 000002FF]	Communications Port (COM2)
[00000378 - 0000037F]	Printer Port (LPT1)
[000003B0 - 000003BB]	Mobile Intel(R) 4 Series Express Chipset Family

[000003C0 - 000003DF]	Mobile Intel(R) 4 Series Express Chipset Family
[000003F0 - 000003F5]	Standard floppy disk controller
[000003F7 - 000003F7]	Standard floppy disk controller
[000003F8 - 000003FF]	Communications Port (COM1)
[00000400 - 000004BF]	Motherboard resources
[000004D0 - 000004D1]	Motherboard resources
[00000500 - 0000051F]	Intel(R) ICH9 Family SMBus Controller - 2930
[00000680 - 000006FF]	Motherboard resources
[00000778 - 0000077B]	Printer Port (LPT1)
[00000880 - 0000088F]	Motherboard resources
[00000A79 - 00000A79]	ISAPNP Read Data Port
[00000D00 - 0000FFFF]	PCI bus
[0000A000 - 0000AFFF]	Intel(R) ICH9 Family PCI Express Root Port 1 - 2940
[0000C000 - 0000CFFF]	Intel(R) ICH9 Family PCI Express Root Port 6 - 294A
[0000CF00 - 0000CF1F]	Intel(R) 82574L Gigabit Network Connection
[0000D000 - 0000DFFF]	Intel(R) ICH9 Family PCI Express Root Port 5 - 2948
[0000DF00 - 0000DF1F]	Intel(R) 82574L Gigabit Network Connection #2
[0000EC00 - 0000EC0F]	Intel(R) ICH9M/M-E 2 port Serial ATA Storage Controller 2 - 292D
[0000ED00 - 0000ED0F]	Intel(R) ICH9M/M-E 2 port Serial ATA Storage Controller 2 - 292D
[0000EE00 - 0000EE03]	Intel(R) ICH9M/M-E 2 port Serial ATA Storage Controller 2 - 292D
[0000EF00 - 0000EF07]	Intel(R) ICH9M/M-E 2 port Serial ATA Storage Controller 2 - 292D
[0000F000 - 0000F003]	Intel(R) ICH9M/M-E 2 port Serial ATA Storage Controller 2 - 292D
[0000F100 - 0000F107]	Intel(R) ICH9M/M-E 2 port Serial ATA Storage Controller 2 - 292D
[0000F300 - 0000F30F]	Intel(R) ICH9M/M-E 2 port Serial ATA Storage Controller 1 - 2928
[0000F400 - 0000F40F]	Intel(R) ICH9M/M-E 2 port Serial ATA Storage Controller 1 - 2928

C.2 <Memory Address Map>

[00000000 - 0009FFFF]	System board
[000A0000 - 000BFFFF]	Mobile Intel(R) 4 Series Express Chipset Family
[000A0000 - 000BFFFF]	PCI bus
[000C0000 - 000DFFFF]	PCI bus
[000E0000 - 000EFFFF]	System board
[000F0000 - 000FFFFF]	System board
[00100000 - 7BC8FFFF]	System board
[7BC90000 - 7BCFFFFF]	System board
[7BD00000 - 7BDFFFFF]	System board
[7BD00000 - FEBFFFFF]	PCI bus
[D0000000 - DFFFFFFF]	Mobile Intel(R) 4 Series Express Chipset Family
[E0000000 - EFFFFFFF]	Motherboard resources
[FD000000 - FD3FFFFF]	Mobile Intel(R) 4 Series Express Chipset Family
[FD600000 - FD6FFFFF]	Intel(R) ICH9 Family PCI Express Root Port 1 - 2940
[FDA00000 - FDAFFFFF]	Intel(R) ICH9 Family PCI Express Root Port 6 - 294A
[FDB00000 - FDBFFFFF]	Intel(R) ICH9 Family PCI Express Root Port 6 - 294A
[FDBC0000 - FDBDFFFF]	Intel(R) 82574L Gigabit Network Connection
[FDBFC000 - FDBFFFFF]	Intel(R) 82574L Gigabit Network Connection
[FDC00000 - FDCFFFFF]	Intel(R) ICH9 Family PCI Express Root Port 5 - 2948
[FDD00000 - FDDFFFFF]	Intel(R) ICH9 Family PCI Express Root Port 5 - 2948
[FDDC0000 - FDDDFFFF]	Intel(R) 82574L Gigabit Network Connection #2
[FDDFC000 - FDDFFFFF]	Intel(R) 82574L Gigabit Network Connection #2
[FDE00000 - FDEFFFFF]	Intel(R) ICH9 Family PCI Express Root Port 1 - 2940
[FDFF4000 - FDFF7FFF]	Microsoft UAA Bus Driver for High Definition Audio
[FDFFD000 - FDFFD0FF]	Intel(R) ICH9 Family SMBus Controller - 2930
[FDFFE000 - FDFFE3FF]	Intel(R) ICH9 Family USB2 Enhanced Host Controller - 293A
[FDFFF000 - FDFFF3FF]	Intel(R) ICH9 Family USB2 Enhanced Host Controller - 293C
[FEB00000 - FEBFFFFF]	Mobile Intel(R) 4 Series Express Chipset Family
[FEC00000 - FEC00FFF]	System board
[FED00000 - FED000FF]	System board
[FED13000 - FED1FFFF]	System board
[FED20000 - FED9FFFF]	System board
[FEE00000 - FEE00FFF]	System board
[FFB00000 - FFB7FFFF]	System board
[FFB80000 - FFBFFFFF]	Intel(r) 82802 Firmware Hub Device
[FFF00000 - FFFFFFFF]	System board

C.3 <System IRQ Resources>

(ISA) 0	System timer
(ISA) 1	Standard 101/102-Key or Microsoft Natural PS/2 Keyboard
(ISA) 3	Communications Port (COM2)
(ISA) 4	Communications Port (COM1)
(ISA) 6	Standard floppy disk controller
(ISA) 8	System CMOS/real time clock
(ISA) 9	Microsoft ACPI-Compliant System
(ISA) 13	Numeric data processor
(PCI) 11	Intel(R) ICH9 Family SMBus Controller - 2930
(PCI) 16	Intel(R) 82574L Gigabit Network Connection #2
(PCI) 16	Intel(R) ICH9 Family PCI Express Root Port 1 - 2940
(PCI) 16	Intel(R) ICH9 Family PCI Express Root Port 5 - 2948
(PCI) 16	Intel(R) ICH9 Family USB Universal Host Controller - 2937
(PCI) 16	Mobile Intel(R) 4 Series Express Chipset Family
(PCI) 17	Intel(R) 82574L Gigabit Network Connection
(PCI) 17	Intel(R) ICH9 Family PCI Express Root Port 6 - 294A
(PCI) 18	Intel(R) ICH9 Family USB Universal Host Controller - 2936
(PCI) 18	Intel(R) ICH9 Family USB2 Enhanced Host Controller - 293C
(PCI) 19	Intel(R) ICH9 Family USB Universal Host Controller - 2939
(PCI) 19	Intel(R) ICH9 Family USB Universal Host Controller - 2935
(PCI) 19	Intel(R) ICH9M/M-E 2 port Serial ATA Storage Controller 1 - 2928
(PCI) 19	Intel(R) ICH9M/M-E 2 port Serial ATA Storage Controller 2 - 292D
(PCI) 21	Intel(R) ICH9 Family USB Universal Host Controller - 2938
(PCI) 22	Microsoft UAA Bus Driver for High Definition Audio
(PCI) 23	Intel(R) ICH9 Family USB Universal Host Controller - 2934
(PCI) 23	Intel(R) ICH9 Family USB2 Enhanced Host Controller - 293A

Appendix D <Programming GPIO's>

The GPIO can be programmed with the MSDOS debug program using simple IN/OUT commands. The following lines show an example how to do this.

GPIO0...GPIO7 bit0.....bit7

```
-o 2E 87                ;enter configuration
-o 2E 87
-o 2E 2A
-o 2F FD                ;enable GPIO function
-o 2E 07
-o 2F 07                ;enable GPIO configuration
-o 2E F0
-o 2F xx                ;set GPIO as input/output; set '1' for input,'0'for output
-o 2E F1
-o 2F xx                ;if set GPIO's as output, in this register its value can be set
```

Optional :

```
-o 2E F2
-o 2F xx                ; Data inversion register ; '1' inverts the current value of the bits , '0'
                        leaves them as they are
-o 2E 30
-o 2F 01                ; active GPIO's
```

For further information, please refer to Winbond W83627THG datasheet.

Appendix E <Watch Dog timer Setting >

The watchdog timer makes the system auto-reset while it stops to work for a period. The integrated watchdog timer can be setup as system reset mode by program.

Timeout Value Range

- 1 to 255
- Second or Minute

Program Sample

Watchdog timer setup as system reset with 5 second of timeout

```

2E, 87
2E, 87
2E, 07
2F, 08      Logical Device 8
2E, 30      Activate
2F, 01
2E, F5      Set as Second*
2F, 00
2E, F6      Set as 5
2F, 05

```

* Minute: bit 3 = 0; Second: bit 3 = 1

You can select Timer setting in the BIOS, after setting the time options, the system will reset according to the period of your selection.



Contact Information

Any advice or comment about our products and service, or anything we can help you please don't hesitate to contact with us. We will do our best to support you for your products, projects and business

Taiwan Commate Computer Inc.

Address	19F., No.94, Sec. 1, Xintai 5th Rd., Xizhi Dist., New Taipei City 22102, Taiwan
TEL	+886-2-26963909
Website	http://www.commell.com.tw
E-Mail	info@commell.com.tw (General Information) tech@commell.com.tw (Technical Support)

Commell is our trademark of industrial PC division